



Main features

Printing type



Barcode



Logos



Alphanumeric text

Maximum height



0-15 mm



16-100 mm



Above 100 mm

Printing surfaces



Primary packaging



Secondary packaging



Raw material

- ▶ Compact design for easy set-up and movement between production lines.
- ▶ Stainless Steel structure AISI 304.
- ▶ Up to 3 lines coding with height from 0,8 to 12 mm.
- ▶ Advanced hydraulic system with high efficiency and reliability and automatic visible double flushing with solvent recycling.
- ▶ Fast consumable changeover with no need to stop production.

Z3000

TECHNICAL SPECIFICATIONS

PRINTING CHARACTERISTICS

- Up to 3 lines of print
- Character height from 0,8 to 12 mm (0,032" - 0,47")
- Line speed capability: up to 400 mt/min (1320 ft/min)
- Print rate: up to 2136 ct/sec
- 100 messages storage
- 250 characters storage per message
- Selectable lines vertical gap
- Font Matrix: 5x4, 5x5, 7x4, 7x5, 9x7 10x8 e 16x10
- Bold factor up to 8 times
- Logo creation and printing
- 30 Logos storage
- Automatic calendar and expiration date print
- Incremental/decreasing Product counter up to 9 digits
- Repeat print – message function
- Printing in all moving directions
- Coding throw distance up to 90 mm (3,54")

BAR CODES

- 2/5 Industrial, UPC-A, CODE39, EAN 13

CONTROL UNIT CHARACTERISTICS

- Membrane keyboard solvent resistant
- Blue WYSIWYG Display with high contrast 240x128 pixels
- Stainless Steel structure AISI 304
- IP53 rating
- Conduit length: 2 mt (6,56 ft)

GENERAL FEATURES

- Single START/STOP button
- Automatic cleaning in Start/Stop procedures
- Automatic Viscosity and Temperature control
- New simplified hydraulic system for low solvent consumptions
- Print parameters storage in the messages
- Operator Multi - Level password access
- Operator interface with foreign languages
- Broad range of inks available (including MEK-free)

PRINTHEAD

- Serviceable and replaceable
- Hermetically sealed structure
- Automatic droplets diagnostic
- Dimensions: 227 mm x 42 mm x 49 mm (9,0" x 1,7" x 1,9")
- Conduit inlet at 90° (optional)
- Internal Supply Positive Air Function
- Micro Nozzle for high quality resolution print (optional)

EXTERNAL CONNECTIONS

- Serial port: RS232
- Sensor management for product detection
- Single bit for print direction
- System ready output
- Shaft encoder input for variable speed production lines
- External alarm outputs with traffic light column

ENVIRONMENT/ELECTRICAL REQUIREMENTS

- Temperature: 5° - 45° C (40°-113°F)
- Humidity: 10-90% (non - condensing)
- Single Phase, 85-240 Vac, 50-60 Hz, 85 VA

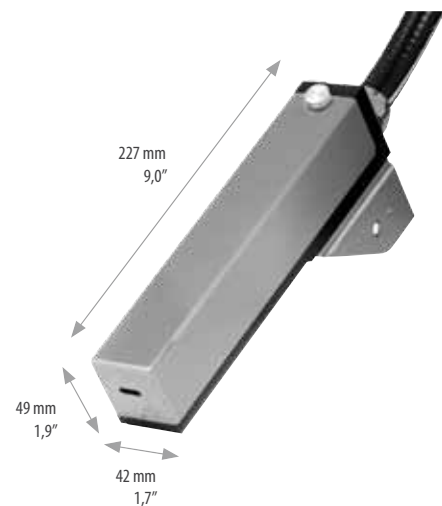

Use a QR code reader to see the product page

Zanasi S.r.l.
Via Marche, 10
41049 Sassuolo (MO) Italy
Tel. +39 0536 999711
Fax +39 0536 999765
www.zanasi.it - info@zanasi.it

Zanasi USA
www.zanasiusa.com

Zanasi China
www.zanasichina.com

 **ZANASI**[®]
make your mark
www.zanasi.it